

THE INFORMATION CONTAINED IN THIS DRAWING IS THE SOLE PROPERTY OF METAL GOODS MANUFACTURING. ANY REPRODUCTION IN PART OR WHOLE WITHOUT THE WRITTEN PERMISSION OF METAL GOODS MANUFACTURING IS PROHIBITED.

REV.	DESCRIPTION	DATE

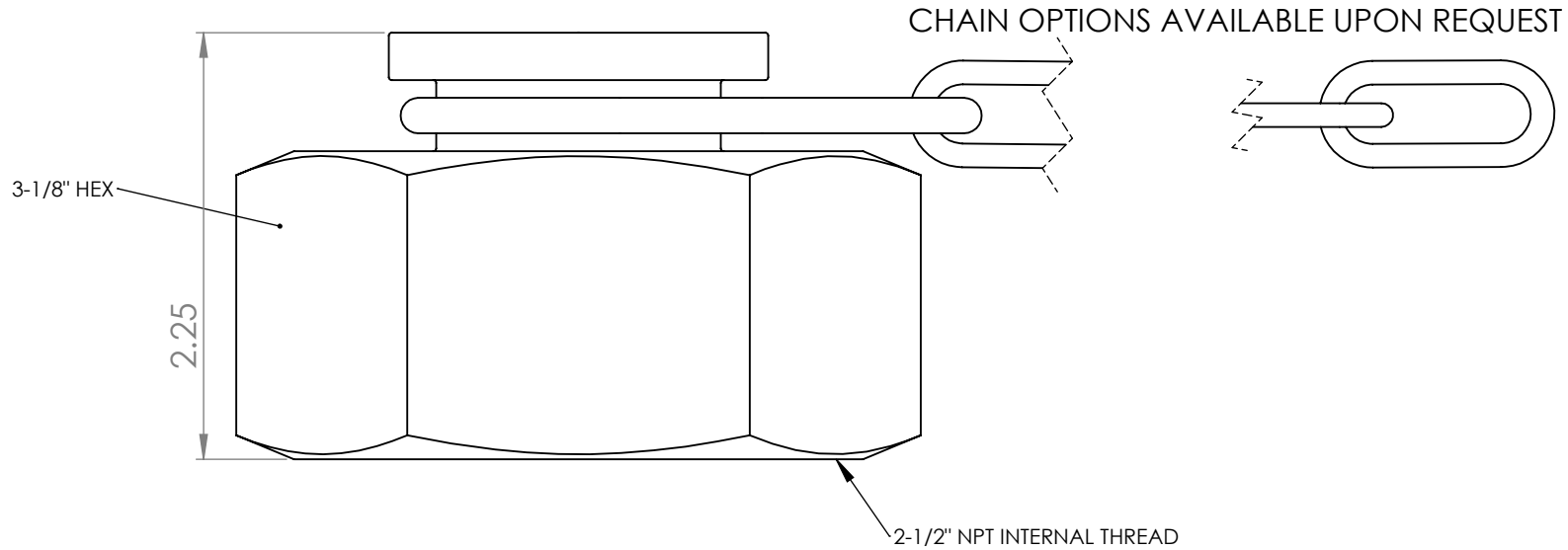

542J 2-1/2" CAP AND CHAIN

CAN BE MANUFACTURED IN THE FOLLOWING MATERIALS

- CARBON STEEL
- 304 STAINLESS
- 316 STAINLESS
- NITRONIC 60
- MONEL 400 & 500 SERIES

OTHER MATERIALS ARE AVAILABLE UPON REQUEST

UNLESS OTHERWISE SPECIFIED
DIMENSIONS ARE IN INCHES
TOLERANCES ARE:
FRACTIONS DECIMALS ANGLES
+/- .015 .XX +/- .015 + 1
.XXX +/- .005

CAD GENERATED DRAWING,
DO NOT MANUALLY UPDATE

APPROVALS	DATE
DRAWN S. STONER	2-25-21
CHECKED	

MATERIAL

FINISH --

DO NOT SCALE DRAWING

REVISED BY	
MFG ENG	
QUAL ENG	

METAL GOODS MANUFACTURING
428 W. 8TH STREET
BARTLESVILLE, OK. 74003 (918) 336-4282

**542J 2-1/2" NPT CAP
WITH RING AND CHAIN**

SIZE	DWG. NO.	REV.
A	542J	
SCALE	PART NO.	SHEET:
1:1	TC-542J-CCA	2